

Collection : Style Rétro

Centrale thermostatique (55 l/min) - Thermostatic mixer (55l/mn)

Ref : M00-2T7

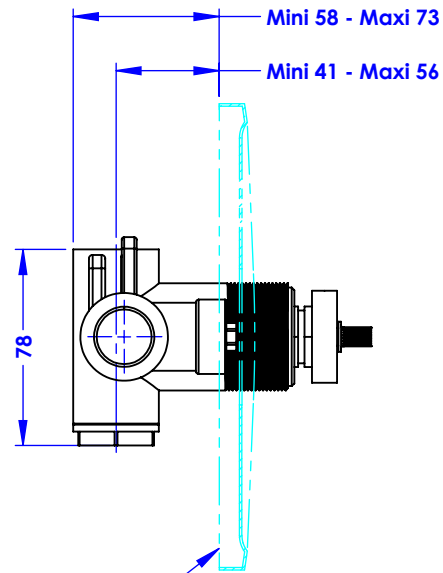
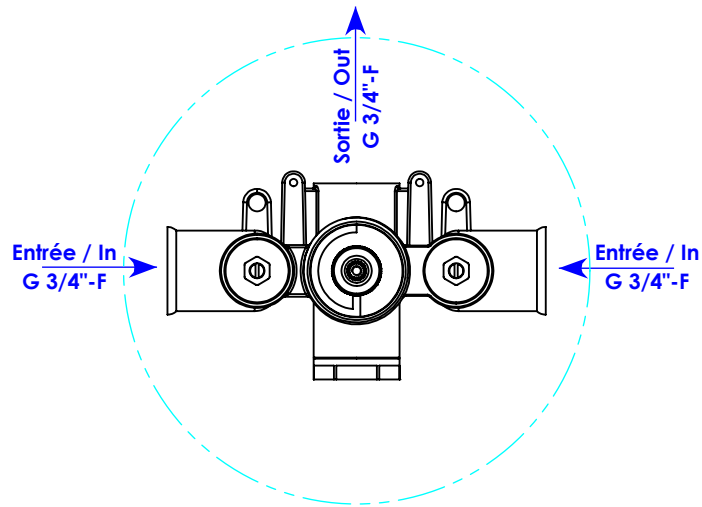
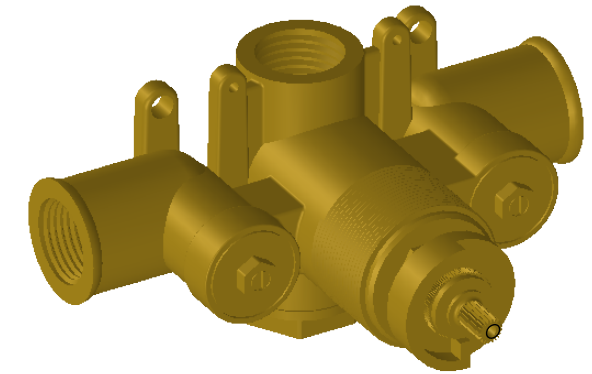

Plaque habillage ronde / Round cover plate
"Rétro"

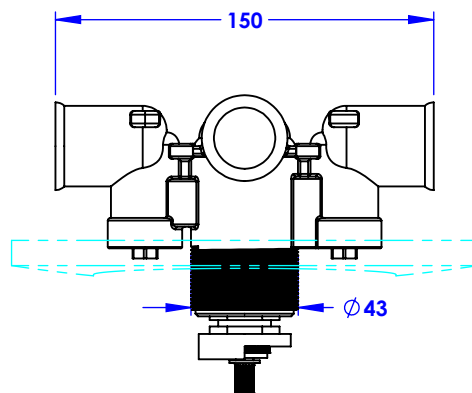

Débit / Flow rate : 55 l/min sous 3 bars.
Pression maxi / max pressure : 5 bars.

Ø de perçage et entre-axe recommandés.
Ø Recommended drilling and centre distances.

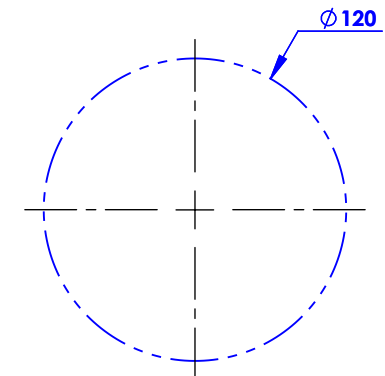

MARGOT

PARIS . 1912

23/02/2022

Collection : Style Contemporain

Centrale thermostatique (55 l/min) - Thermostatic mixer (55l/mn)

Ref : M00-2T7

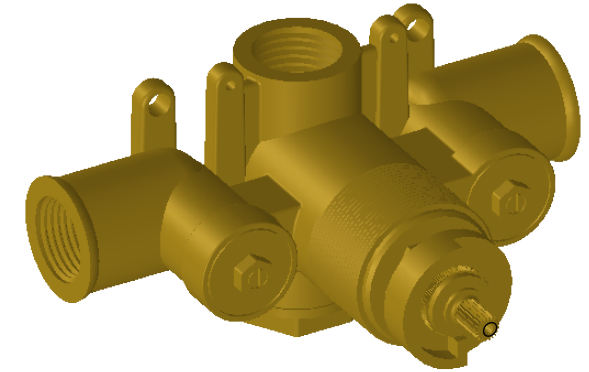
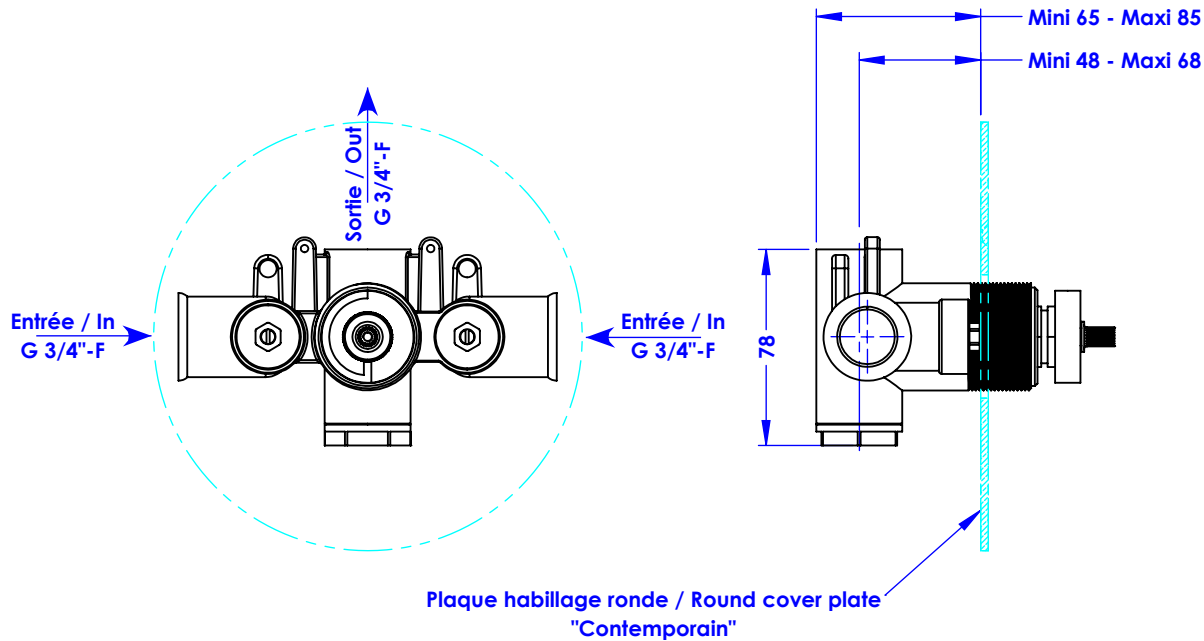

Débit / Flow rate : 55 l/min sous 3 bars.
Pression maxi / max pressure : 5 bars.

Ø de perçage et entre-axe recommandés.
Ø Recommended drilling and centre distances.

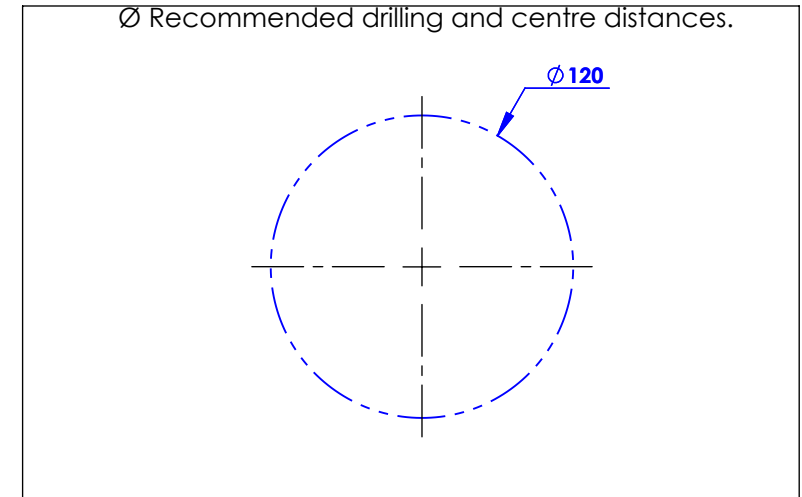
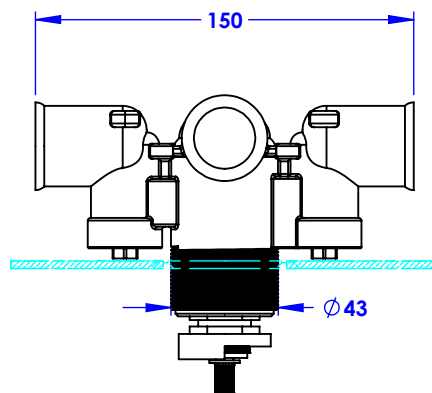

MARGOT

PARIS . 1912

23/02/2022